



A Graphic Detail Reference for Concrete Slab & Foundation Planning

These Guidelines are based on Common Construction Practice, Engineering Guidelines and Existing Code Standards for the general design of a variety of common foundation and slab assemblies. They are intended for Project Planning Purposes Only and Do Not represent Engineering Solutions for Foundation Design.

Developed and Organized by R.Tom Compton, AIA

www.RTomCom.com

Table of Contents

Sheet Index

TITLE PAGE and NOTATION SYMBOL KEY & INDEX _____ PAGE 0.0

INDEX of FOUNDATIONS and DETAILS _____ PAGE 0.1

The foundation categories defined in these guidelines have been adopted to organize the types of assemblies commonly used in both commercial and residential construction. It is the intent of this document to continue to add variations to these basic assemblies and add new types over time. Please provide feedback on the information within and make suggestions for new types for inclusion to RTom@RTomCom.com.

Ref. Sym.

 GENERAL NOTES: _____ PAGE 0.2

General notes for all details are located on this page keyed by a number designation, inside a hexagon symbol.

 SOIL AND BACKFILL MATERIAL STANDARDS: _____ PAGE 0.3

Soil and Backfill notes for all details are located on this page keyed by a letter designation, inside a square symbol.

 COMMON NOTES and FOUNDATION STANDARDS: _____ PAGE 0.4 & 0.5

General notes for all details are located on this page keyed by a letter & number designation, inside a triangle symbol.

STATEMENT OF PURPOSE

These guidelines are the result of an expanding assembly of practical knowlege & information on slab and foundation assemblies of various types. As such, it does not represent or replace required project specific design processes. This information is intended to provide the builder and designer with a graphic tool showing the basic characteristics, performance standards and limitations of a variety of foundation types. By having a clearer understanding of what constitutes a properly implemented foundation it is the intent of this document to literally improve the "Foundation" of the construction industry, improving performance, comfort, efficiency and long term sustainability.

These Guidelines are Based on Existing Code and Common Practice Standards

Foundation Type Table of Contents

Sheet Index

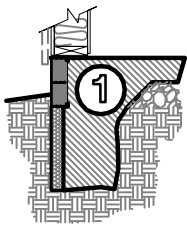

TYPE 1.0

- **FOUNDATION TYPE 1.0, Mono Pour Foundation & Slab:** — PAGE 1.0
1.0 General MONO-POUR assembly standards.

These types of foundations are generally used in areas with very shallow or no frost depth. They also tend to be more common in area with arid conditions. This is because after "trenching" the perimeter may stand opened while "groundwork" is put in place. If rain is common, these trenches are exposed to damage and over hydration, impacting bearing performance. This assembly is generally a "ONE Pour" process.

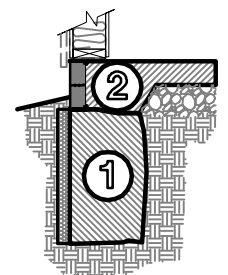

TYPE 2.0

- **FOUNDATION TYPE 2.0 Grade Beam & Slab:** — PAGE 2.0
2.0 General GRADE BEAM & SLAB assembly standards.

These types of foundations are generally more common in mid-range climate zones and "non-inhabited" outbuildings. They allow for a simple "grade beam" or "trench" foundation and the placement of a, typically 8", thickened edge slab on top. While cost effective, this approach can be inaccurate and somewhat difficult to accurately insulate or "form" a straight and level perimeter. This assembly is generally a "TWO Pour" process.

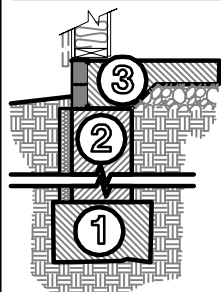

TYPE 3.0

- **FOUNDATION TYPE 3.0 Foundation, Stemwall & Slab:** — PAGE 3.0

This foundation assembly is most common. It is used in nearly every climate zone and there are numerous variations. Its assembly consists of a poured footing with a formed stemwall on top followed by placement of a, typically 8" thickened concrete slab on top or a poured slab within the stemwall. This type of assembly is very flexible in connecting various building conditions and elevations into one organized foundation solution. This assembly is generally a "THREE Pour" process.

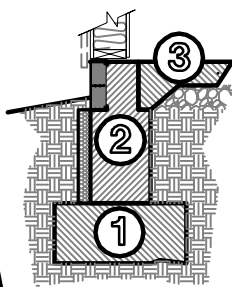

TYPE 3.1

- **FOUNDATION TYPE 3.1 Frost Wall & Slab:**

This 3.0 assembly variation is more common in colder climates where placement of the slab can be accomplished at a later phase in a project after enclosure or in commercial applications where tenant spaces can be secured prior to slab placement.

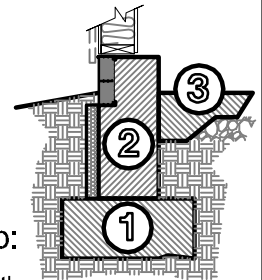

TYPE 3.2

- **FOUNDATION TYPE 3.2 Frost Wall & Offset Slab:**

This 3.0 assembly variation allows for raised "curb" for placement of the framing wall above the slab for grading and/or allowance for a sloping slab poured inside the "frost-wall" perimeter.

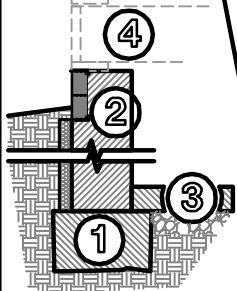

TYPE 4.0

- **FOUNDATION TYPE 4.0 Basement Foundation:** — PAGE 4.0

This assembly is common for buildings with finished floor area below grade. The variations, interfaces and number building elements required for this assembly to function properly are complex but the floor space it yield is very economical and in some areas necessary for storm protection. Its use is wide-spread across all climate zones.

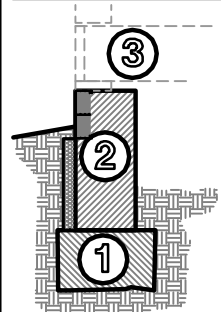

TYPE 5.0

- **FOUNDATION TYPE 5.0 Other Foundation Assemblies:** — PAGE 5.0

This assembly is common for buildings constructed on sites with uneven or otherwise unstable soil conditions that make slab placement difficult. The resulting crawl space, while allowing for easy installation of utilities also presents moisture and temperature challenges. Its use is widespread across all climate zones.

- **FOUNDATION SECTION & DETAIL STANDARDS:** — PAGES 6.0 - 6.2
Supplemental and Alternative Details.

- **FOUNDATION & SLAB SITE CONDITIONS:** — PAGE 7.0
This section addressed environmental impacts on foundation, slab placement and long term performance. Those impacts include soil type, moisture and thermal variables.

IMPORTANT NOTE: Details in this reference material are not to scale. They are intended to represent general construction assemblies for the purpose of identifying minimum construction standards. As such, the user must evaluate each project and circumstance applying higher performance, as may be required, to insure that both the safety and quality of the final product reflects and promotes the integrity of the construction industry.

STANDARDS:

01 PURPOSE OF GUIDELINES

These guidelines are intended to provide designers, contractors and architects with information in evaluating foundation alternatives. They identify basic assembly elements and reasonable projections for determining the material requirements for implementing solid foundation and slab design concepts. Information includes conceptual design data for construction of concrete foundations and slabs including code compliant, and recommended design standards. These standards include new construction and additions to existing structures and were originally developed as minimum building standards for Wichita Kansas & surrounding areas. It is always the responsibility of the contractor to evaluate the scope and circumstances of each project and retain professional advise on any areas of concern including foundation and slab design.

02 HIGHLY RECOMMENDED SOIL ANALYSIS:

GENERAL MAKEUP OF EXISTING SITE SOILS: It is highly recommended that a native soil be taken from at least two locations on your building site to determine soil type and characteristics. Each soil sample should be approximately 8oz to 12oz sealed in a zip-lock plastic bag. Sample material should be taken from 12" to 18" below grade at diagonal corners within footprint of proposed structure or addition. A plasticity index (PI) report from soils engineer is a routine test. This PI report helps establishes the minimum required depth of footings recommended by these guidelines.

03 PLASTICITY INDEX AND FOOTING DEPTH THE IMPACT OF A SOILS PLASTICITY INDEX (PI) ON FOUNDATIONS:

Native soil type and characteristics impact the performance of foundations. These variations in the soil effect frost depth, expansiveness, movement and are generally set in motion as a result of the amount of moisture to which these soil types subjected. Variations of moisture levels can cause dramatic soil movement capable of damaging even well designed foundation systems. Soil material content can range widely in a very small area depending on the geographical region. Refer to sheet 7.0 for the effects of very expansive soil on foundations & slabs.

04 SITE & FOUNDATION MOISTURE

THE CONTROL OF SURFACE DRAINAGE IS CRITICAL IN MINIMIZING THE POTENTIAL FOR FOUNDATION DAMAGE AS A RESULT OF MOISTURE: Proper building site pad elevation and strict adherence to the overall sub-division development drainage plan is mandatory.

In the absence of such an engineered drainage plan it is recommended that professional input on building site development be retained. While many uncontrollable environmental factors influence soil conditions including weather, vegetation and exposure, poorly sited buildings with poor drainage plans are most susceptible to water & foundation damage.

05 OWNER EDUCATION ON MAINTENANCE: OWNERSHIP OF PROPERTIES REQUIRES UPKEEP AND MAINTENANCE:

It is natural for soil materials at the perimeter of a building to settle over time. This settlement is ongoing and takes place over many years. In much the same up-keep sequence as painting, owners of properties should accept the fact that additional soil material will be required to maintain proper surface drainage. Good drainage away for the building perimeter, including downspout and sump pump extensions will minimize the threat of foundation problems resulting from water trapped against the slab or basement wall edges.

06 SITE CONDITIONS FOR PLACEMENT:

REFERENCE SHEET 7.0: Soil "b" material acts as both a leveling element for the slab and as a buffer against the movement characteristics of Soil "a". Increasing the depth of Soil "b" with increased PI rating of below grade soils is ALWAYS recommended. Consult a professional if PI soil materials above 45 or if site conditions suggest questionable or inconsistent bearing performance circumstances.

07 FIBER REINFORCING:

Fiber materials are intended as a shrinkage and non-structural cracking control additive. These materials do not replace the requirements for steel reinforcing wire fabric materials or reinforcing bar, etc. Consult a design professional for recommendations on appropriate fiber material performance.

08 TECHNICAL INSTALLATION STANDARDS:

The contractor assumes responsibility for construction techniques, methods, standards and solutions implemented under his direction. He further assumes responsibility for recognizing and building in accordance with adopted codes, standards and guidelines as well as following the plans and specific recommendations of professionally prepared documents and specifications, if any, for a specific project. If criteria is found to be in conflict, use the more stringent standard or consult a licensed design professional.

09 CONCRETE INSPECTIONS:

Basic to construction practice includes knowledge of local standards, code and inspection processes. Become familiar with code and construction standards in project area.

10

Foundation **LOADING LEVEL DEFINITIONS** used in this report refer to **LEVEL I, LEVEL II and LEVEL III** loading levels. The basic assumptions include span and tributary loading as defined in the graphic below. This summary is intended as a guideline for estimation of requirements and does not replace the need for a licensed structural engineers analysis. Where spans exceed the "max" spans cited, structural consultation is recommended.

See Common Note E2
Structural Engineering

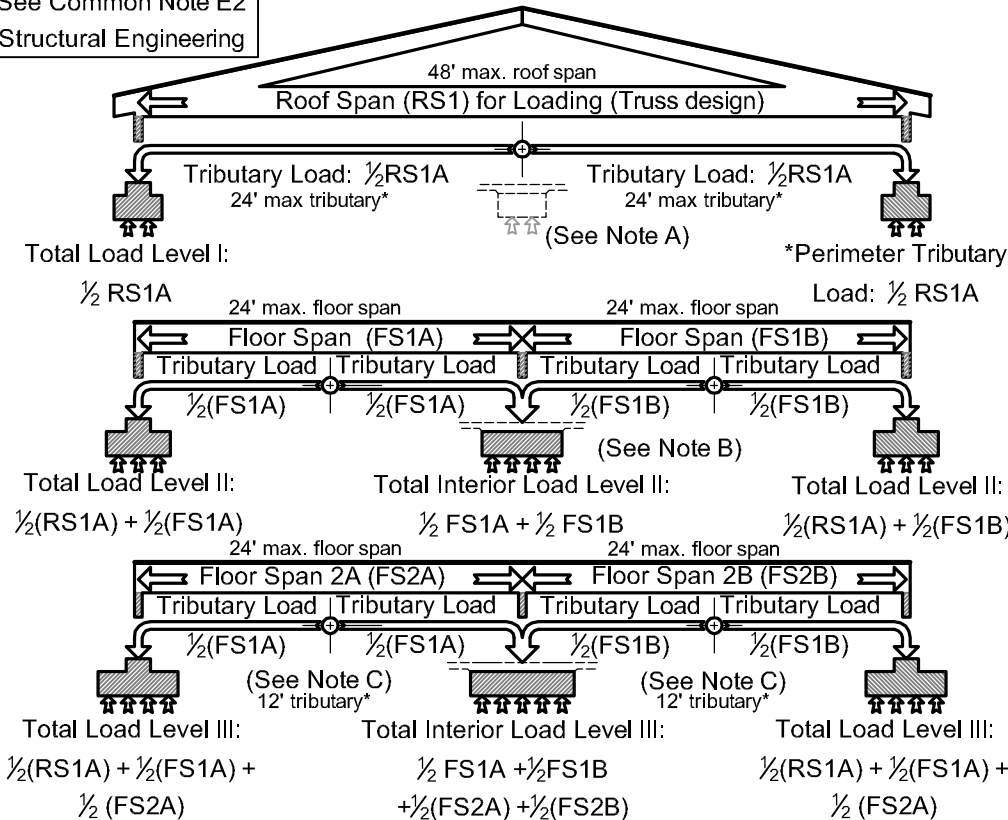

LEVEL I LOADING: ROOF ONLY

Defined in this report as a structure with a roof load only, or a single story slab-on-grade, or crawl space building. (Note A: Roof systems may also use interior bearing footings.)

LEVEL II LOADING: ROOF + 1 FLOOR

Defined in this report as a roof load with one floor load, or a typically two story building.

(Note B: Interior footings must carry the weight of tributary loads from each side.)

LEVEL III LOADING: ROOF + 2 FLOOR

Defined in this report as a roof load with two floor loads, or a typically three story building.

(Note C: As roof and floor loads increase so does footing dimension & reinforcing.)

(Note D: The lowest level can also be a basement (i.e. making a two story home with a basement a Level III foundation Load)

*Tributary loading is used to calculate the weight distributed from each span to supporting walls and ultimately into the foundation. A tributary dimension is typically half the span and includes a combined dead load (DL), or construction material weight + live load (LL) which includes snow loading on roof areas or furniture and human loading in floor areas. Local and national codes provide minimum design DL + LL criteria and are influenced greatly by climate (snow loading is a most notable variable). Each floor plus the roof load is added together to determine a design load necessary for the foundation to carry. Other loading considerations for foundation design include the weight of wall and exterior finishing materials (masonry veneers being a most notable factor).

SOIL & BACKFILL MATERIAL STANDARDS:

Soil a EXISTING SITE SOILS: See General note D2 for required analysis of local existing, native soil. This analysis is required in order to establish PI index which determines minimum required depth foundation assembly below finished grade.

Soil b BELOW SLAB FILL MATERIAL: COMPACTED Sand, Pea Gravel, or other approved Stabilizing Materials (i.e. Similar to Soil Type "f" in this standards).















Soil c FINISH GRADE MATERIAL: Topsoil. See Common note D2 for required slope away from foundation perimeter and Common note B3 for required dimension below top of concrete wall or finished slab elevation.

Soil d FOUNDATION BACKFILL MATERIAL: Backfill with loose, uniform soil preferably slightly damp. Use only material that is free from organic material, debris and large clumps (6" max.). Fill perimeter uniformly in lifts of 24" maximum. If additional soil materials from off site are required, soil shall be of some makeup as local material, See Soil Type "a".

Soil e FOUNDATION FILL MATERIAL AT FOOTING DRAINAGE MATERIAL: Coarse washed sand or washed river rock. Do not use fine sand fill material on exterior drainage tile.

Soil f LOW VOLUME FILL MATERIAL: Any type of engineered fill material designed to deliver predictable compaction & bearing performance as well as low expansive reactions in response to variation in moisture.

COMMON NOTES FOR FOUNDATION STANDARDS:

-  A1 Footings shall be continuous on all sides of structure with bearing in minimum 1500 psf undisturbed soil or a controlled and tested fill.
-  A2 Do not place patio or driveway slabs on the fill next to ANY wall unless supported either on supporting ledges, on dowels or by supporting columns carried down to the adjacent footings bottom.
-  A3 Ufer ground shall be installed in all structural footings. Contact inspection department for criteria for proper installation.
-  B1 Do not backfill an unsupported straight run of wall over 16' in length (Measured between corners and cross walls or supporting buttresses) unless adequate bracing is provided or the floor framing has been set in place and anchor bolts tightened. Reference details D1 & D2, sht 6.1.
-  B2 Backfill only against sufficiently reinforced and cured concrete. No heavy wheel loading adjacent to the wall shall be allowed. Basement walls are NOT designed as retaining walls, reference details A2, sht 6.0 for laterally unsupported wall design criteria.
-  B3 There shall be a minimum dimension from finished grade to top of concrete foundation or slab of 6" minimum. If sod is to be installed adjacent the foundation, this dimension shall be 8" minimum to allow for depth of sod material.
-  B4 Surround the drain tiles with 12" min. depth and width of coarse washed sands (Road gravel). Crushed limestone is not acceptable. All drain tile shall be 3" or 4" and covered with sock or filter cloth. See Soil Type "e".
-  B5 Excavated soil material shall not be used as fill below concrete slabs including garage slabs unless properly placed, and tested for bearing performance. Imported material used for fill below any slab shall be of soil type B or as specified by a licensed professional consultant. All fill shall be distributed below concrete slabs in layers, filling all voids, with each properly compacted in sequence.
-  B6 Vegetation and organic top soil material shall be completely removed from building site areas to receive concrete slab and foundation assemblies. Do not place slab fill and preparation materials over organic materials.
-  C1 All concrete shall have a minimum 28 days compressive strength of 3500 psi for exterior slabs and 3000 psi for interior slabs, walls and footings.
-  C2 Concrete shall have a 5" maximum slump at the end of the chute or an 8" maximum slump if a high range water reducer is added.
-  D1 Exterior and Interior drain tiles shall be continuous around footings placed as illustrated with silt protective "sock". Interior and exterior systems shall be independent with no connection. Interior and Exterior systems may discharge into same sump pump pit or gravity flow to exterior discharge. Insure that the discharge location provides for positive drainage away from foundation edge. Mechanically pumped discharge should include pipe or solid trough that carries drain-water least past the original basement over-dig or 5' whichever is greater. (Ref Detail E2/6.1 for secondary sump installation option.)
-  D2 To assure adequate drainage away from the foundation, grade away from the foundation shall slope at a recommended rate of 1" per ft. for 6 ft. minimum. Positive drainage shall then be maintained beyond in accordance with the development drainage plan. All drainage shall be maintained at a 1/4" per ft. minimum. Use of soil type "c", organic top soil, is limited to 4" within 6' of perimeter to insure a positive drainage "cap" of native material below. Backfill below the topsoil layer, whether on-site or imported, materials, shall be consistent in make-up to existing local soil materials generally equal to Soil Type "a".
-  D3 Site irrigation systems adjacent foundations present a substantial source for the introduction of moisture into expansive sub-soils and resulting damage. Systems should be routinely balanced, inspected and maintained to limit and control this risk.
-  D4 Underslab utilities shall be installed with at least a 4" cover of compacted sand material between the bottom of the slab and top of utility line.

(COMMON NOTES CONTINUED ON PAGE 0.5)

COMMON NOTES FOR FOUNDATION STANDARDS:

(COMMON NOTES CONTINUED FROM PAGE 0.2)

E1 Basement walls above 9'-0" in height, measured from top of footing to top of concrete wall should be designed and sealed by a licensed design professional.

E2 Foundation **LOADING LEVEL DEFINITIONS** include maximum span and tributary loading limits as defined in the graphics on General Notes Sheet 0.3. Spans or loading conditions in excess of these "LEVELS" shall be reviewed by a licensed design professional in the same region as the project under review.

F1 Seal tie holes and cracks with fiber sealant before dampproofing.

F2 One coat dampproofing minimum shall be applied in soils with PI of 15 and below and two coats, or equivalent shall be applied in all soil types with PI above 15. Waterproofing material shall extend from top of wall to base of wall and horizontally on top of footing to seal joint a wall base.

R1 All horizontal bars shall lap a minimum of 18" at ends, splices, and around corners.

R2 Set anchor bolts at the spacing shown on the wall sections in attached drawing, preferably set by templates secured to the forms before concrete is placed, to assure proper placement. Details illustrate the use of embedded anchoring bolts typically. It is acceptable to use adhesive or mechanical anchoring systems drilled in place that are properly engineered and manufactured to function in this capacity.

R3 The placement of vertical and horizontal steel shall be in accordance with specific foundation type standards documented in these standards. Reference foundation type.

R4 Reinforcing mesh shall overlap a minimum of 6" and shall extend to within 3" of perimeter edge of concrete. The use of proper positioning devices for slab reinforcing (mesh or rebar) is encouraged, however, pulling reinforcing, where applicable, to the proper final location is acceptable.

R5 Where slab construction in poured adjacent foundation walls forming an unsupported "floating slab" (Similar to Det F1/6.2), 1/2" min. diameter reinforcing bars, 16" min. in length spaced at 32" max o.c., shall be drilled a minimum of 4" into perimeter bearing wall and extend into the center of the adjacent slab. Thicken edge of slab as required for 1 1/2" coverage of rebar top and bottom. Rebar material may be smooth.

R6 Mechanical attachment assemblies for hold-down, shear and other requirements specific to regional environmental exposures are not addressed in this document. The inclusion of reinforcing materials in these details is included to follow the intent of this document, a guideline outlining the normal material dimensions, quantities and placement that might be expected for normal design conditions. Structural engineering review of these assumptions is necessary prior to consecution.

T1 The IRC/IECC-2006 requires minimum insulation performance at various elements of exterior construction assemblies. Foundation and Slab Insulation standards are included for climate zones 4 and above. We recommend including this standard beginning in zone 3. Inclusion of this insulation performance is an important element in completing a buildings thermal envelope and should not be omitted. This insulation improves not only the energy performance of the building but allows for the even distribution of heat from wall to wall, improving comfort. Energy Star® requires insulation on all foundation types including slab-on-grade. If no insulation is installed as per the standard, a zero must be disclosed. The following table shows insulation values for the various types of foundations based on ICC 2009 building & energy codes:

TABLE A - FOUNDATION INSULATION STANDARDS		
Typical of Climate Zones 4 thru 8 in the U.S.		
Construction Type	Continuous or Framing	
* Foundation Insulation	R-10	R-13
Crawl Space Insulation	R-10	R-13
Slab Insulation	R-10 to a min 24" depth	

* See Detail E1/6.1 for basement foundation insulation options

T2 IRC/IECC-2009 code requires that exposed R10 insulation at the slab edge be protected from damage and deterioration when installed. Install perimeter insulation system designed for this purpose providing heavy gauge, durable surface or flashing to protect material transition where exposed between below grade and above grade wall or joist space assemblies. The use of patented EnergyEdge systems at this critical transition will provide both the necessary R10 insulation and an integrally poured-in-place protective shell finish in one installation sequence.

T3 Sill Sealer and Expansion materials used to provide draft and bond breaker functions.

(END OF COMMON NOTES)

FOUNDATION TYPE 1.0 DETAIL NOTES:

- 1a Fndn Type 1.0 / Mono Pour Foundation type.
- 2 For all note "2" dimensional standards (a thru d), reference the table on this page:
- 3 Reference Soil & Backfill standards for these material types:

Soil a	Soil b	Soil c
--------	--------	--------
- 4 Reference specifically these Common Notes for type 1.0 fndn:

A1 thru A3	B3 thru B6	C1	C2	D2 thru D4	R1 thru R5	T1	T2
------------	------------	----	----	------------	------------	----	----
- 5 Steel Reinforcing and anchoring standards:
 - a) 3- #4 horizontal continuous at PI<16, 4- #4 at PI 16+.
 - b) #4 vertical @ 30" o.c. max. centers, center in footing. (Hook 24" into slab)
 - c) Anchor Bolts.
 - d) Slab reinforcement: 6x6-w1.4 x w1.4 WWF (6x6 - 10x10 mesh), center in slab.
 - e) Slab reinforcement: 6x6-w2.9 x w2.9 WWF in sheets (6x6 - 6x6 mesh), center in slab.
 - f) Slab reinforcement: #4 @ 24" o.c. each way, center in slab or approved post tensioning system.
- 6 All foundations must extend 12" min. into undisturbed soil free of vegetation or into engineered controlled fill materials. Foundations or grade beams may also be supported on concrete piers extending into deeper bearing material. These systems to be designed and sealed by a Kansas design professional.
- 7 Min. 2x4 PL w/ 1/2" dia. anchor embeded 7" into slab edge at 36" o.c. max. with washer & nut. One anchor within 12" of each end & splices. Optional anchors shall be designed and sealed by a design professional.

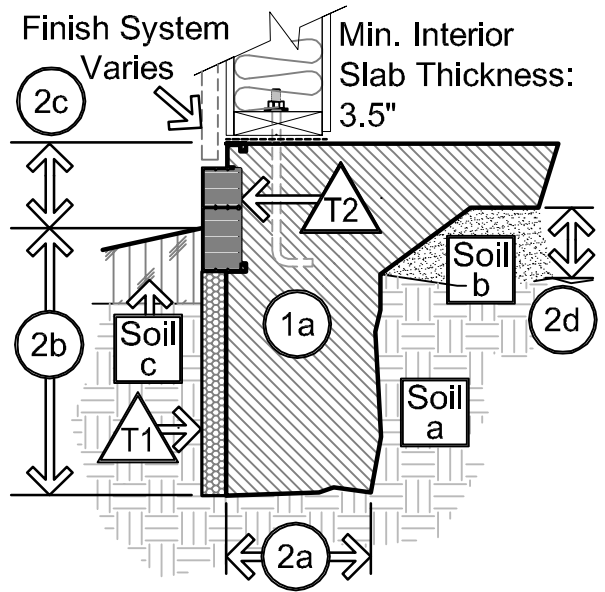

Soil Type	(2a)	(2b)	(2c)	(2d)	Reinforcing
Sandy/Silts PI <16	See note below	FD min.	6" min. above grade	4" min.	Ref detail #1 below
Sandy Clay/Clay PI 16 to 30	for min. widths	+6"	finish	4" min.	Ref detail #2 below
Lean/Fat Clay PI 31 to 45		FD +12"		6" min.	Ref detail #3 below

Consult a licensed design professional where PI > 45.
 Note on foundation widths: Level I loading = 8"; Level II loading = 12"; Level III loading = 16"; Add 4" to all min dimensions with addition of brick ledge. (Reference common note E2/Sht 0.3 for Load Level Definitions.)

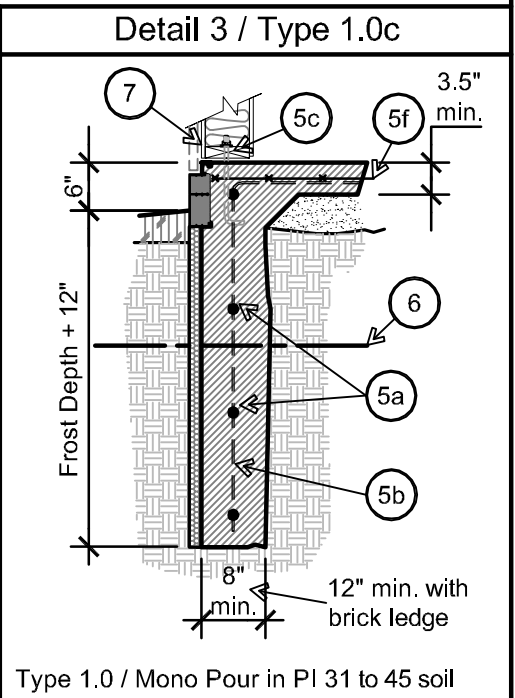
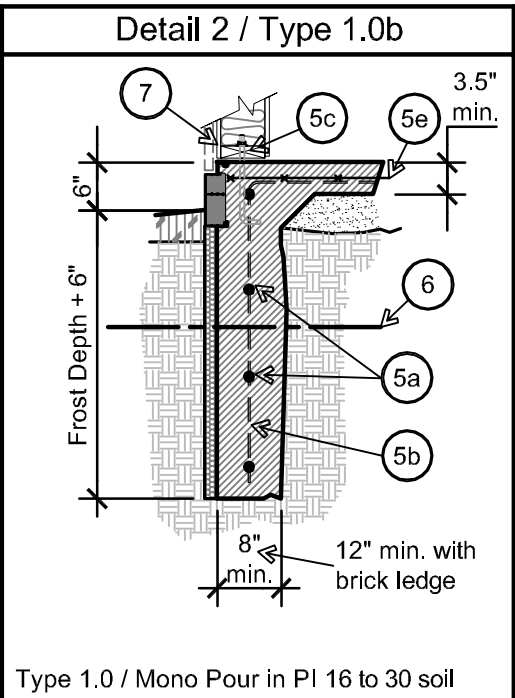
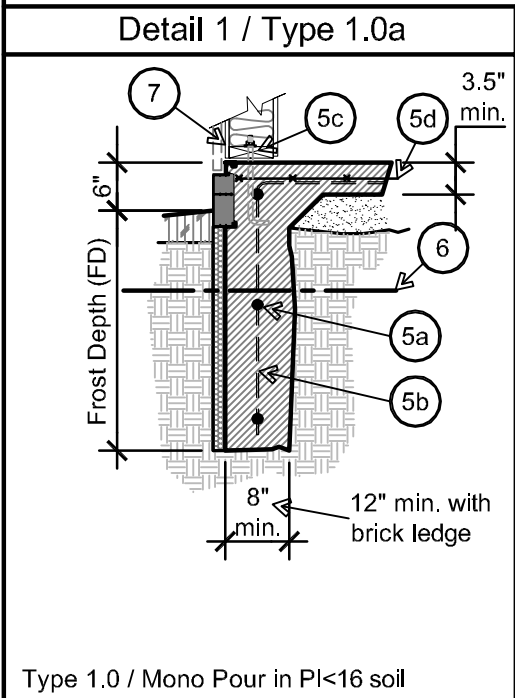

Type 1.0 / Mono Pour in PI<16 soil Type 1.0 / Mono Pour in PI 16 to 30 soil Type 1.0 / Mono Pour in PI 31 to 45 soil

- FOUNDATION TYPE 2.0 DETAIL NOTES:**
- 1a Fndn Type 2.0 / Grade Beam (Trench) & Slab placement.
 - 1b 8" thickened edge slab.
 - 2 For all note "2" dimensional standards (a thru g), reference the table on this page:
 - 3 Reference Soil & Backfill standards for these material types:

Soil a	Soil b	Soil c
--------	--------	--------
 - 4 Reference specifically these Common Notes for type 2 fndn:

A1 thru A3	B3	C1	C2	D2 thru D4	R1 thru R5	T1	T2
------------	----	----	----	------------	------------	----	----
 - 5 Steel Reinforcing and anchoring standards:
 - a) 3- #4 horizontal continuous at PI<16, 4- #4 at PI 16+.
 - b) #4 vertical @ 30" o.c. max. centers, centered in footing. (Hook 24" into slab)
 - c) Anchor Bolts.
 - d) Slab reinforcement: 6x6-w1.4 x w1.4 WWF (6x6 - 10x10 mesh), center in slab.
 - e) Slab reinforcement: 6x6-w2.9 x w2.9 WWF in sheets (6x6 - 6x6 mesh), center in slab.
 - f) Slab reinforcement: #4 @ 24" o.c. each way, center in slab or approved post tensioning system.

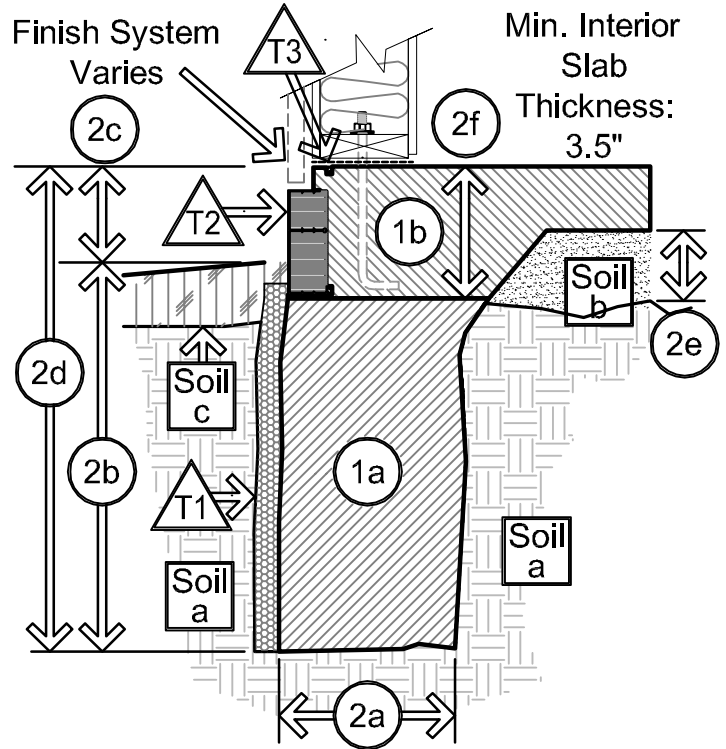

Dimension and Reinforcing Requirement Table / Type 2.0							
Soil Type a	(2a)	(2b)	(2c)	(2d)	(2e)	(2f)	Reinforcing
Sandy/Silts PI <16	See note below for min. widths	30" min.	6" min.	FD min.	4" min.	8" min.	Ref detail #1 below
Sandy Clay/Clay PI 16 to 30		36" min.	6" min.	FD +6"	4" min.	8" min.	Ref detail #2 below
Lean/Fat Clay PI 31 to 45		42" min.	6" min.	FD +12"	6" min.	8" min.	Ref detail #3 below

Consult a licensed design professional where PI > 45.
 Note on foundation widths: Level I loading = 8"; Level II loading = 12"; Level III loading = 16"; Add 4" to all min dimensions with addition of brick ledge. (Reference common note E2/Sht 0.3 for Load Level Definitions.)

- 6 All foundations must extend 12" min. into undisturbed soil free of vegetation or into engineered controlled fill materials. Foundations or grade beams may also be supported on concrete piers extending into deeper bearing material. These systems shall be designed and sealed by a Kansas design professional.
- 7 Min. 2x4 PL w/ 1/2" dia. anchor embedded 7" into slab edge at 36" o.c. max. with washer & nut. One anchor within 12" of each end & splices. Optional anchors shall be designed and sealed by a design professional.

Detail 1 / Type 2.0a	Detail 2 / Type 2.0b	Detail 3 / Type 2.0c
<p style="text-align: center;">Type 2.0 / Grade Beam in PI <16 soil</p>	<p style="text-align: center;">Type 2.0 / Grade Beam in PI 16 to 30 soil</p>	<p style="text-align: center;">Type 2.0 / Grade Beam in PI 31 to 45 soil</p>

FOUNDATION TYPE 3.0 DETAIL NOTES:

- 1a Fdn Type 3.0 / Footing 1b Stemwall 1c 8" thicken edge Slab.
- 2 For all note "2" dimensional standards (a thru g), reference the table on this page:
- 3 Reference Soil & Backfill standards for these material types:

Soil a	Soil b	Soil c	Soil d
--------	--------	--------	--------
- 4 Reference specifically these Common Notes for type 3 fndn:
- 5 Steel Reinforcing and anchoring standards:
 a) 3- #4 horizontal continuous at PI<16, 4- #4 at PI 16+. One bar in slab.
 b) #4 vertical @ 30" o.c. max. centers, center in wall. (Hook 24" into slab)
 c) Anchor Bolts.
 d) Slab reinforcement: 6x6-w1.4 x w1.4 WWF (6x6 - 10x10 mesh), center in slab.
 e) Slab reinforcement: 6x6-w2.9 x w2.9 WWF in sheets (6x6 - 6x6 mesh), center in slab.
 f) Slab reinforcement: #4 @ 24" o.c. each way, center in slab or approved post tensioning system.
 g) #4 dowels @ 30" o.c. max. (dowels and verticals could be one piece) 6" leg at bottom.
 h) 2-#4 cont. @ 1'-4" min. ftg. & 3-#4 cont. @ 1'8" min. ftg.
- 6 All foundations must extend 12" min. into undisturbed soil free of vegetation or into engineered controlled fill materials. Foundations or grade beams may also be supported on concrete piers extending into deeper bearing material. These systems must be designed and sealed by a Kansas design professional.
- 7 Min. 2x4 PL w/ 1/2" dia. anchor embeded 7" into slab edge at 36" o.c. max. with washer & nut. Optional anchors shall be designed and sealed by a design professional. One anchor within 12" of each end & splices.

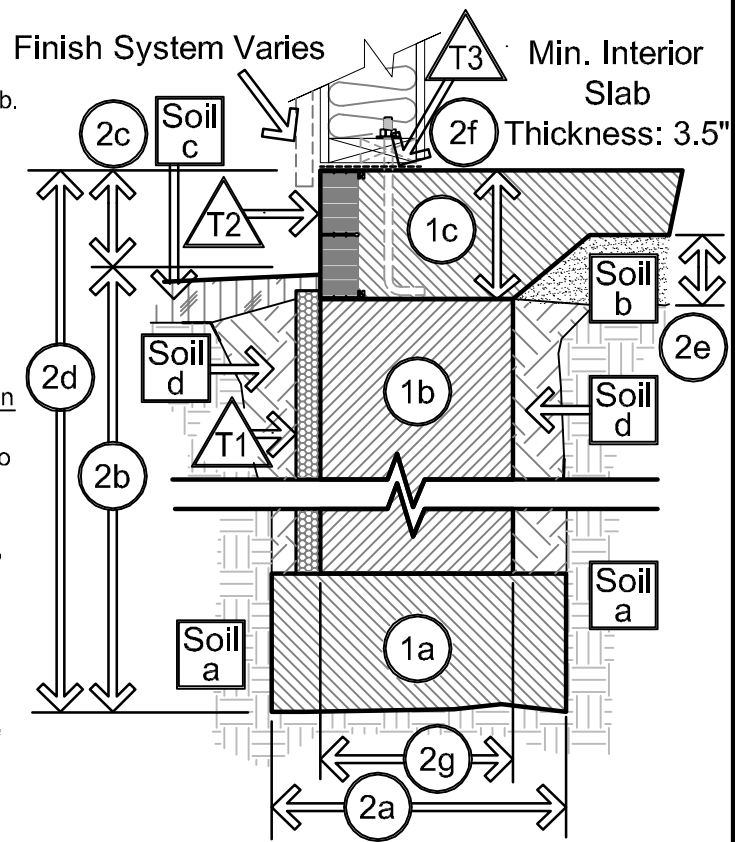

Soil Type a	(2a)	(2b)	(2c)	(2d)	(2e)	(2f)	(2g)	Reinforcing
Sandy/Silts PI <15	See note below	30" min.	6" min.	FD min.	4" min.	8" min.	8" min.	Ref detail #1 below
Sandy Clay/ Clay PI 15 to 35	below for min. widths	36" min.	6" min.	FD +6" min.	4" min.	8" min.	(10" min @ brick ledge)	Ref detail #2 below
Lean/Fat Clay PI >35		42" min.	6" min.	FD +12" min.	6" min.	8" min.	brick ledge)	Ref detail #3 below

Consult a licensed design professional where PI > 45.
 Level I & II loading: 1'-8" min. & 2'-0" min w/ Brick Ledge, at Level III loading: 2'-0" min & 2'-4" w/ Brick Ledge. (See Common Note E2/0.3 for Loading Level)

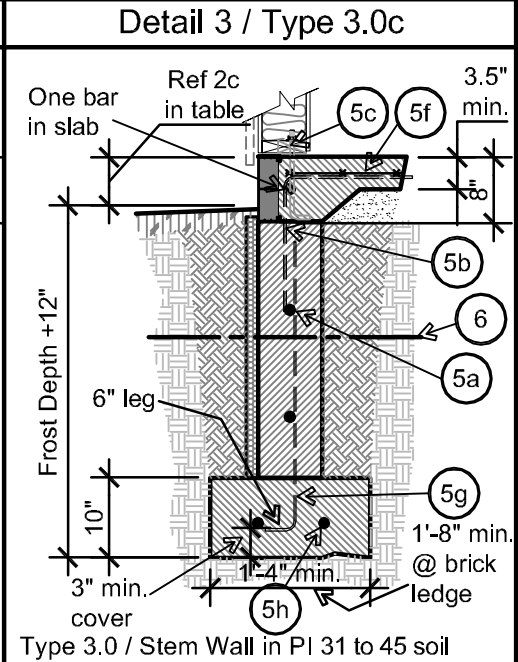
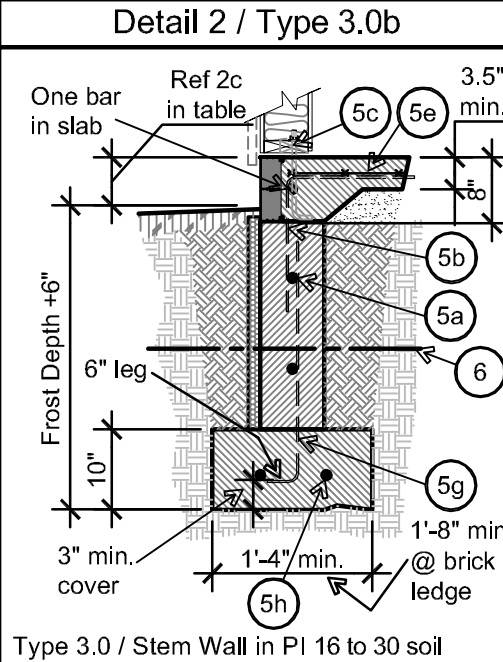
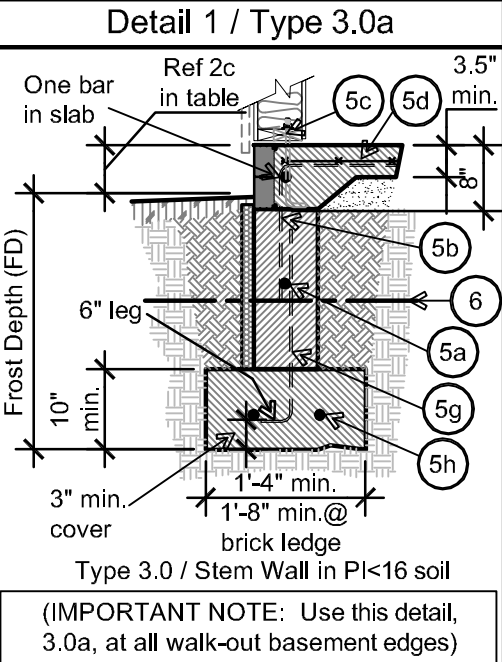

- FOUNDATION TYPE 3.1 DETAIL NOTES:**
- 1a) Fndn Type 3.1 / Footing 1b) Frost Wall 1c) Interior Slab
 - 2) For all note "2" dimensional standards (a thru g), reference the table on this page:
 - 3) Reference Soil & Backfill standards for these material types:

Soil a	Soil b	Soil c	Soil d
-----------	-----------	-----------	-----------
 - 4) Reference specifically these Common Notes for type 3.1 fndn:

▲ A1 thru A3	▲ B3	▲ C1	▲ C2	▲ D2 thru D4	▲ R1 thru R5	▲ T1	▲ T2
--------------------	---------	---------	---------	--------------------	--------------------	---------	---------
 - 5) Steel Reinforcing and anchoring standards:
 a) 3- #4 horizontal continuous at PI<16, 4- #4 at PI 16+.
 b) #4 vertical @ 30" o.c. max. centers. Center in upper wall.
 (Hook 24" into slab)
 c) Anchor Bolts.
 d) Slab reinforcement: 6x6-w1.4 x w1.4 WWF (6x6 - 10x10 mesh), center in slab.
 e) Slab reinforcement: 6x6-w2.9 x w2.9 WWF in sheets (6x6 - 6x6 mesh), center in slab.
 f) Slab reinforcement: #4 @ 24" o.c. each way, center in slab or approved post tensioning system.
 g) #4 dowels @ 30" o.c. max. (dowels and verticals could be one piece)
 - 6) All foundations must extend 12" min. into undisturbed soil free of vegetation or into engineered controlled fill materials. Foundations or grade beams may also be supported on concrete piers extending into deeper bearing material. These systems must be designed and sealed by a Kansas design professional.
 - 7) Min. 2x4 PL w/ 1/2" dia. anchor embeded 7" into slab edge at 36" o.c. max. with washer & nut. One anchor within 12" of each end & splices. Optional anchors shall be designed and sealed by a design professional.

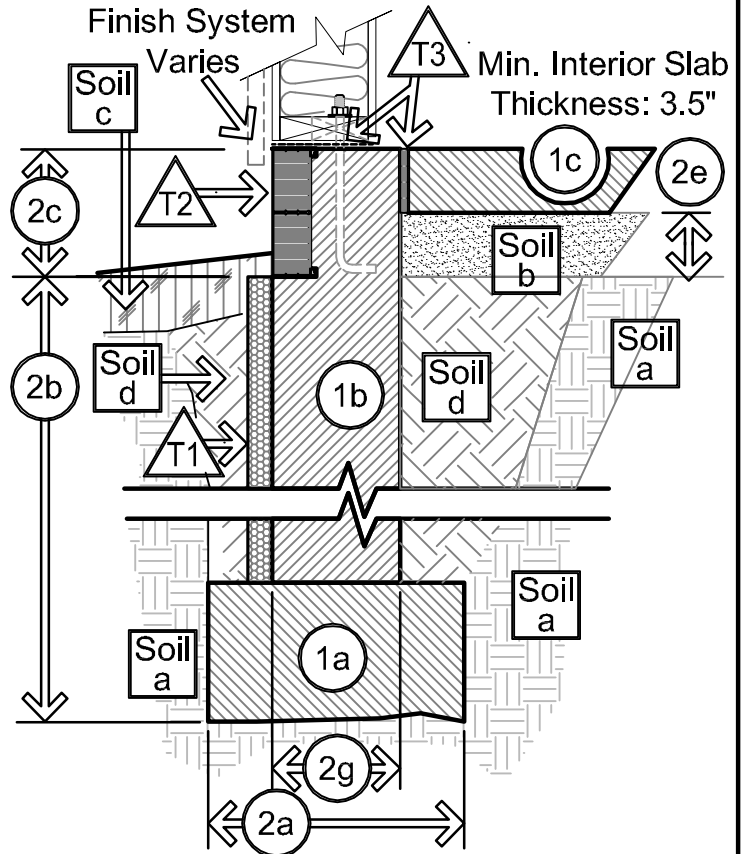

Soil Type a	(2a)	(2b)	(2c)	(2d)	(2e)	(2f)	(2g)	Reinforcing
Sandy/Silts PI <15	See note	FD min.	6" min.		4" min.	8" min.		Ref detail #1 below
Sandy Clay/ Clay PI 15 to 35	below for min.	FD +6"	6" min.	16" min.	4" min.	8" min.	8" min.	Ref detail #2 below
Lean/Fat Clay PI >35	widths	FD +12"	6" min.		6" min.	8" min.		Ref detail #3 below

Consult a licensed design professional where PI > 45.
 Level I & II loading: 1'-8" min. & 2'-0" min w/ Brick Ledge, at Level III loading: 2'-0" min & 2'-4" w/ Brick Ledge. (See Common Note E2/0.3 for Loading Level)

Detail 1 / Type 3.1a	Detail 2 / Type 3.1b	Detail 3 / Type 3.1c
<p>Type 3.1 / Frost Wall in PI < 16 soil</p>	<p>Type 3.1 / Frost Wall in PI 16 to 30 soil</p>	<p>Type 3.1 / Frost Wall in PI 31 to 45 soil</p>

- FOUNDATION TYPE 3.2 DETAIL NOTES:
- 1a) Fndn Type 3.2 / Footing 1b) Frost Wall 1c) Slab at garage
 - 2) For all note "2" dimensional standards (a thru g), reference the table on this page:
 - 3) Reference Soil & Backfill standards for these material types:

Soil a	Soil b	Soil c	Soil d
--------	--------	--------	--------
 - 4) Reference specifically these Common Notes for type 3.1 fndn:

thru A1	thru A3	B3	C1	C2	thru D2	thru D4	thru R1	thru R5	T1	T2
---------	---------	----	----	----	---------	---------	---------	---------	----	----
 - 5) Steel Reinforcing and anchoring standards:
 - a) 3- #4 horizontal continuous at PI<16, 4- #4 at PI 16+.
 - b) #4 vertical @ 30" o.c. max. centers. Center in upper wall.
 - c) Anchor Bolts.
 - d) Slab reinforcement: 6x6-w1.4 x w1.4 WWF (6x6 - 10x10 mesh), center in slab.
 - e) Slab reinforcement: 6x6-w2.9 x w2.9 WWF in sheets (6x6 - 6x6 mesh), center in slab.
 - f) Slab reinforcement: #4 @ 24" o.c. each way, center in slab or approved post tensioning system.
 - g) #4 dowels @ 30" o.c. max. (dowels and verticals could be one piece)
 - 6) All foundations must extend 12" min. into undisturbed soil free of vegetation or into engineered controlled fill materials. Foundations or grade beams may also be supported on concrete piers extending into deeper bearing material. These systems must be designed and sealed by a design professional.
 - 7) Min. 2x4 PL w/ 1/2" dia. anchor embeded 7" into slab edge at 36" o.c. max. with washer & nut. One anchor within 12" of each end & splices. Optional anchors shall be designed and sealed by a design professional.

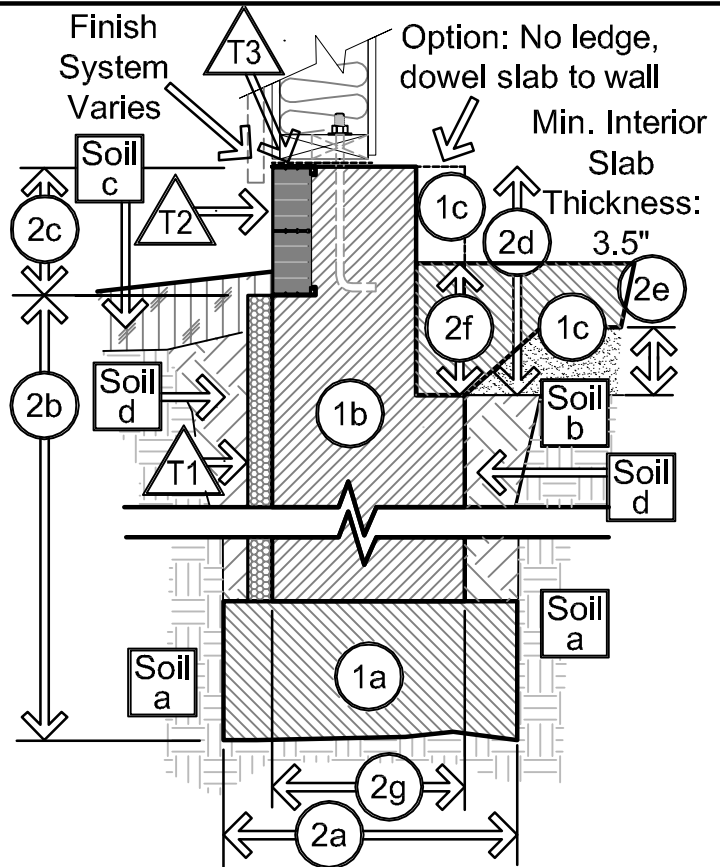

Soil Type a	(2a)	(2b)	(2c)	(2d)	(2e)	(2f)	(2g)	Reinforcing
Sandy/Silts PI <15	See note	FD min.	6" min.		4" min.	8" min.		Ref detail #1 below
Sandy Clay/ Clay PI 15 to 35	below	FD +6"	6" min.	16" min.	4" min.	8" min.	8" min.	Ref detail #2 below
Lean/Fat Clay PI >35	min. widths	FD +12"	6" min.		6" min.	8" min.		Ref detail #3 below

Consult a licensed design professional where PI > 45.
 Level I & II loading: 1'-8" min. & 2'-0" min w/ Brick Ledge, at Level III loading: 2'-0" min & 2'-4" w/ Brick Ledge. (See Common Note E2/0.3 for Loading Level)

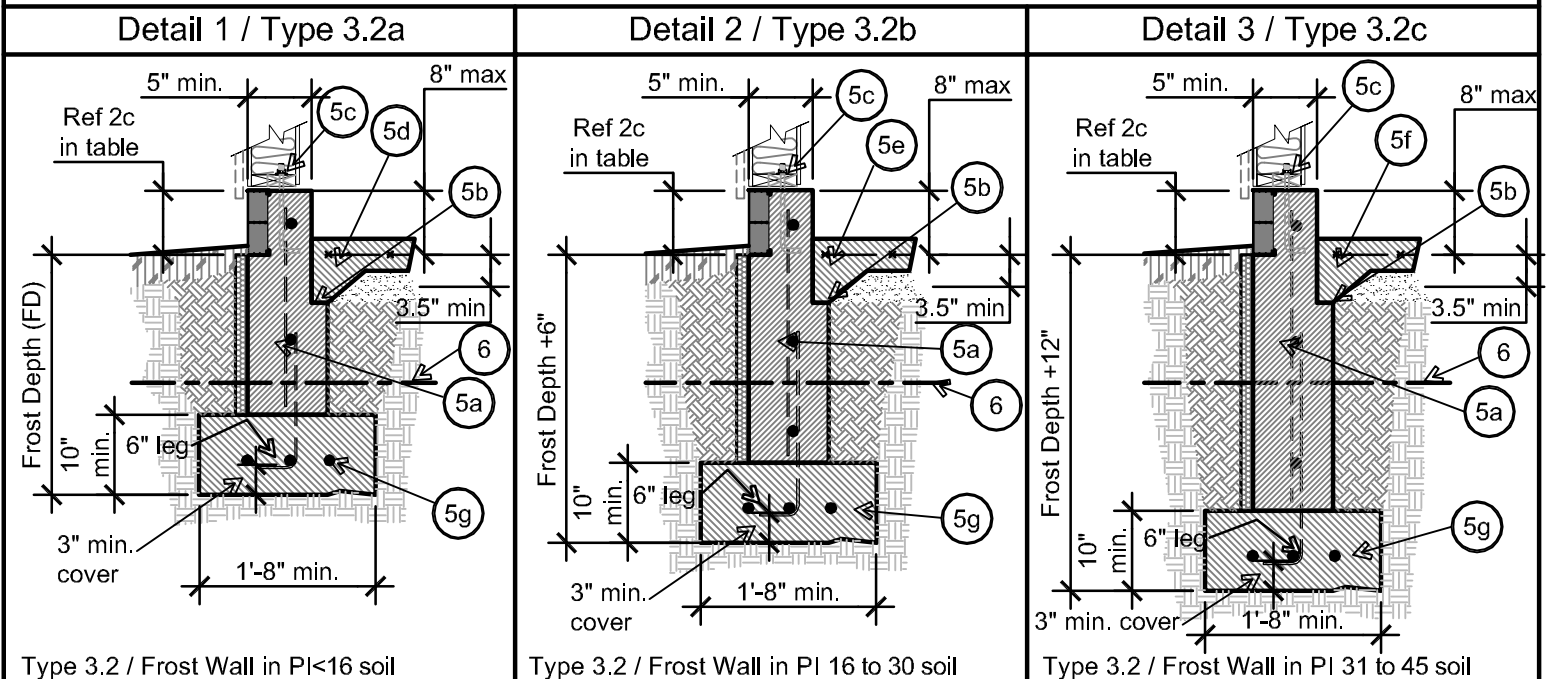

Note Sym Key
 ● general ▲ common
 ○ detail ■ soils

Basement Walls & Foundations

Construction Guidelines (9'-0" max. from top of foundation)

4.0
 FndnType

FOUNDATION TYPE 4.0 DETAIL NOTES:

1a FOUNDATION FOOTING:

1b BASEMENT WALL: Do not backfill any wall before 7 days when average air temperature is above 50 degrees and not before 10 days when average air temperature is below 50 degrees. Reference general note B2

1c BASEMENT SLAB: See note 6.

2 For all note "2" dimensional standards (a thru e), reference the following table:

Soil	8" wall	10" wall
PI < 16	24" o.c.	30" o.c.
PI 16-35	18" o.c.	24" o.c.
PI 36-45	12" o.c.	18" o.c.

Min. treated 2x6 PL w/ 1/2" dia. x10" min. anchor bolts @ 32" o.c. max. or 5/8" dia. x10" min. anchor bolts @ 48" o.c. max. with washer & nuts. (Approved adhesive or mechanical anchors drilled in place are acceptable.) Anchor bolts to be placed at centerline of the sill plate and embedded a minimum of 7" into concrete. A maximum of one plate may be added on top of the

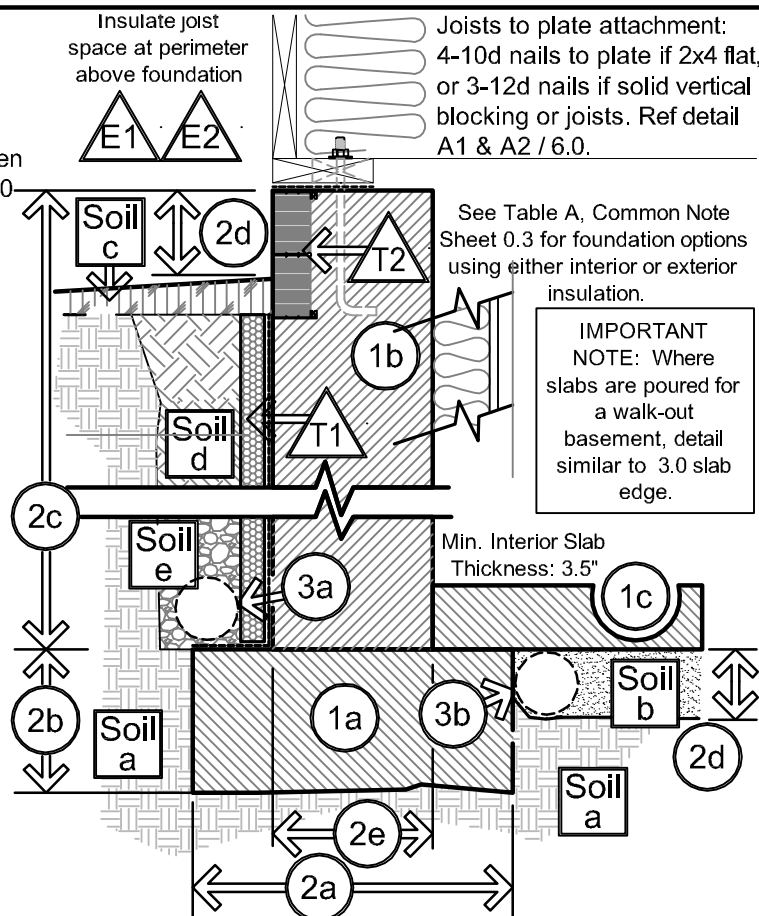
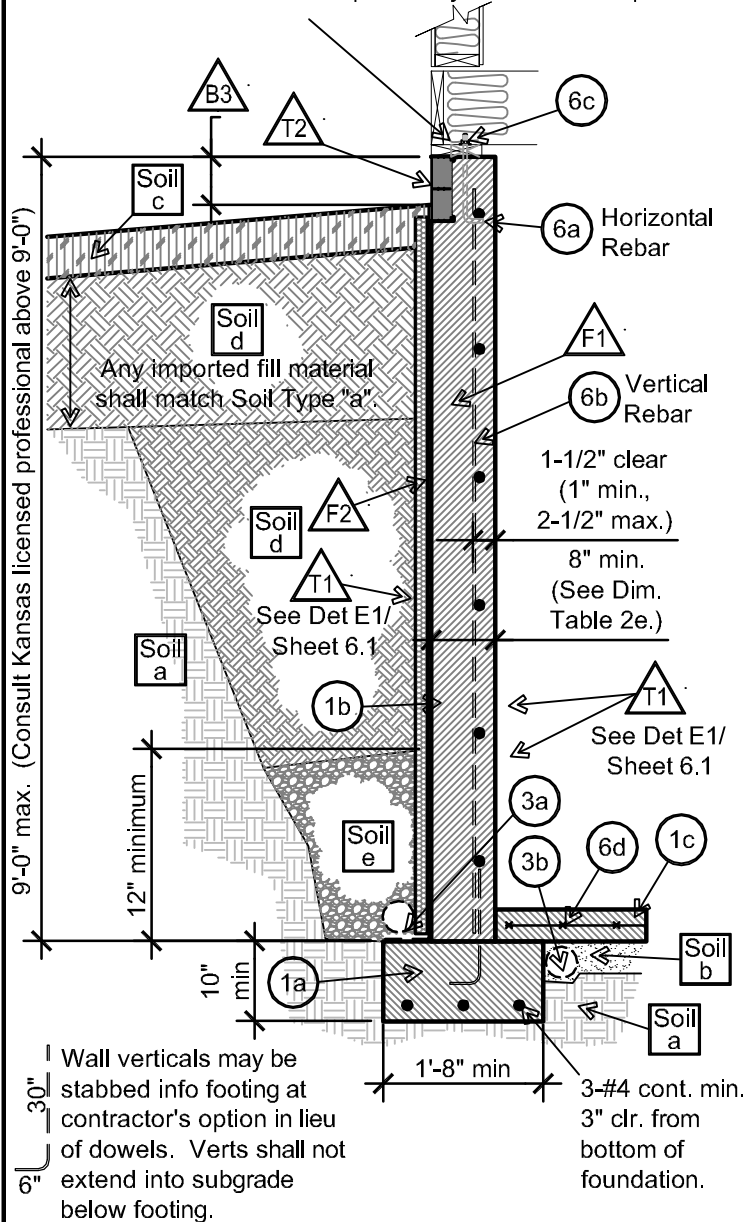

IMPORTANT NOTE: Where slabs are poured for a walk-out basement, detail similar to 3.0 slab edge.

3 3a Exterior Drain Tile & 3b Interior Drain Tile. Reference Common Note D1/Sht 0.2

Soil Type [a]	(2a)	(2b)	(2c)	(2d)	(2e)	Reinforcing
Sandy/Silts PI < 16	20" min.	10" min.	9'-0" max. wall height	4" min.	8" min.	Ref detail this sheet for reinforcing standards
Sandy Clay/Clay PI 16 to 30	(24" min. w/ brick ledge)	10" min.	10" from fndn.	4" min.	(10" min @ brick ledge)	
Lean/Fat Clay PI 31 to 45		10" min.		6" min.		

Consult a design professional where PI > 45.

- 4 Reference Soil & Backfill standards for these material types:
 [Soil a] [Soil b] [Soil c] [Soil d] [Soil e]
- 5 Reference specifically these Common Notes for type 4 fndn:
 ▲A1 ▲A2 ▲B1 thru ▲B6 ▲C1 ▲C2 ▲D1 thru ▲D4
 ▲E1 ▲F1 ▲F2 ▲R1 thru ▲R5 ▲T1 ▲T2
- 6 Steel Reinforcing and anchoring standards:
 - a) #4 horizontal @ 16" o.c. continuous - uppermost bar must be within 8" from top of wall. (Lap 18" min. at all splices & corner bars)
 - b) Reference vertical rebar schedule.
 - c) Anchor Bolts, see common note "R2" and detail this sheet.
 - d) Slab reinforcement: 6x6-w1.4 x w1.4 WWF (6x6 - 10x10 mesh), center in slab.
- 7 Treat slab edges of walk-out basements according to criteria for Type 3.0a/ Stem Wall Det #1. Also reference detail F4/sht. 6.2.

- FOUNDATION TYPE 5.0 DETAIL NOTES:
- 1a FOUNDATION FOOTING:
- 1b CRAWL SPACE STEM WALL: Do not backfill any wall before 7 days.
- 2 For all note "2" dimensional standards (a thru c), reference the following table:

Soil Type a	(2a)	(2b)	(2c)	(2d)	(2e)	Reinforcing
Sandy/Silts PI <16	See note	10" min.	See Details 1 thru 3 below	6" min.	8" min.	Ref detail this sheet for reinforcing standards
Sandy Clay/Clay PI 16 to 30	below for min. widths	10" min.		6" min.	10" min @ brick ledge	
Lean/Fat Clay PI 31 to 45		10" min.		6" min.		

Consult a licensed design professional where PI > 45.

Level I & II loading: 1'-8" min. & 2'-0" min w/ Brick Ledge, at Level III loading: 2'-0" min & 2'-4" w/ Brick Ledge. (See Common Note E2/0.3 for Loading Level)

- 3 Reference Soil & Backfill standards for these material types: Soil a Soil c Soil d
- 4 Reference specifically these Common Notes for type 5 fndn:
 ▲A1 ▲A2 ▲B2 ▲B3 ▲C1 ▲C2 ▲D2 ▲D3 ▲R1 thru R5 ▲T1 ▲T2
- 5 Steel Reinforcing and anchoring standards:
 a) 2- #4 horizontal continuous @ PI<16; 3-#4 horizontal continuous @ PI 16 and above.
 b) #4 vertical @ 30" o.c. max., center in wall (Hook 24" into slab)
 c) Anchor Bolts, see common note "R2" and detail this sheet.
- 6 All foundations must extend 12" min. into undisturbed soil free of vegetation or into engineered controlled fill materials. Foundations or grade beams may also be supported on concrete piers extending into deeper bearing material. These systems must be designed by an architect or engineer.

7 Min. treated 2x6 PL w/ 1/2" dia. x10" min. anchor bolts @ 32" o.c. max. or 5/8" dia. x10" min. anchor bolts @ 48" o.c. max. with washer & nuts. (Approved adhesive or mechanical anchors drilled in place are acceptable.) Anchor bolts to be placed at centerline of the sill plate and embedded a minimum of 7" into concrete. A maximum of one plate may be added on top of the lower plate.

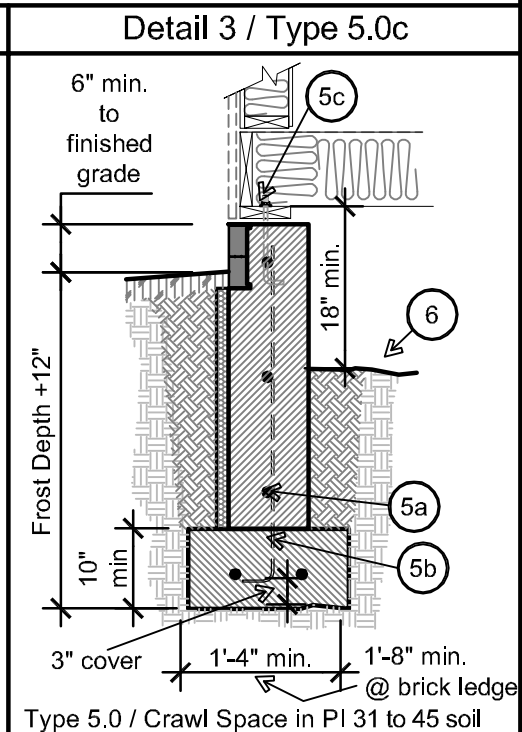
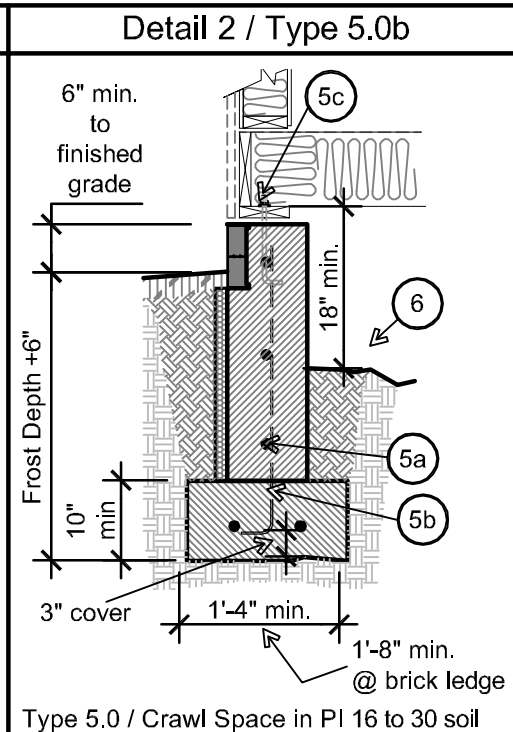
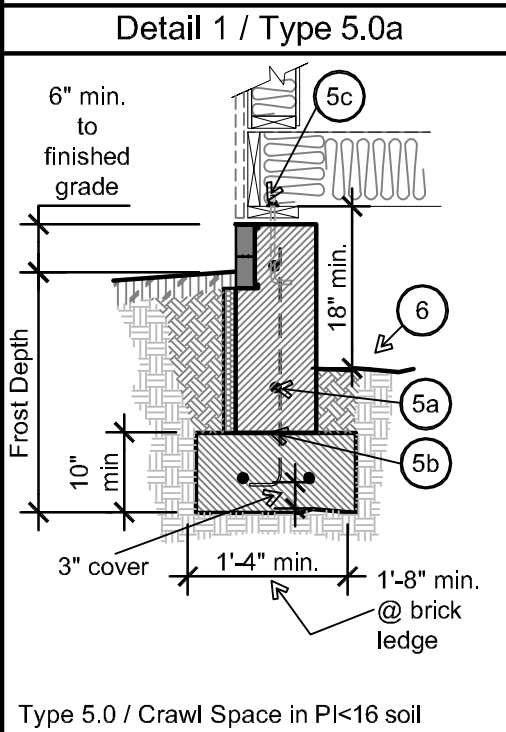
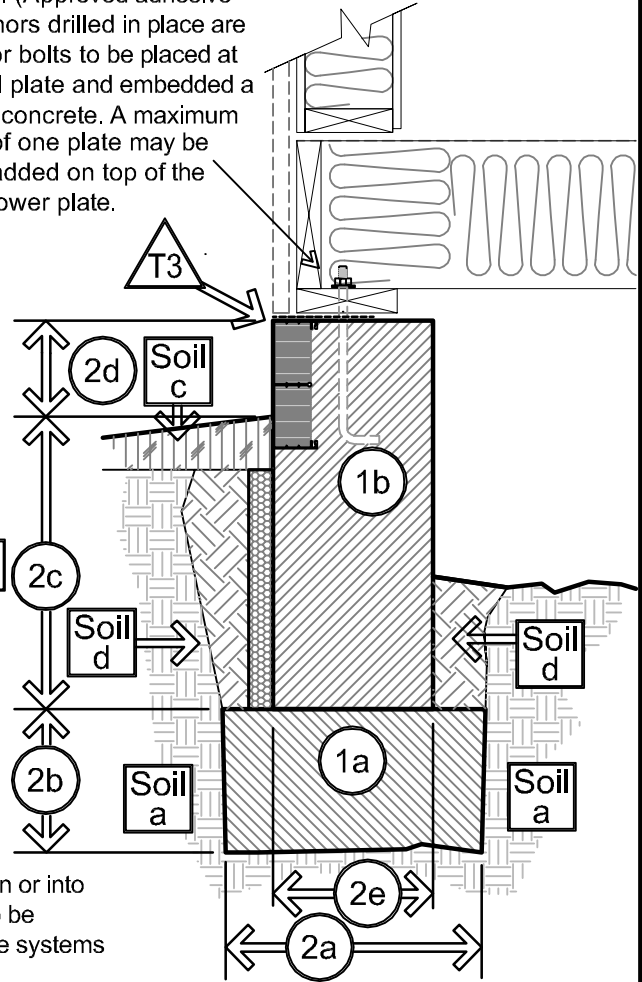

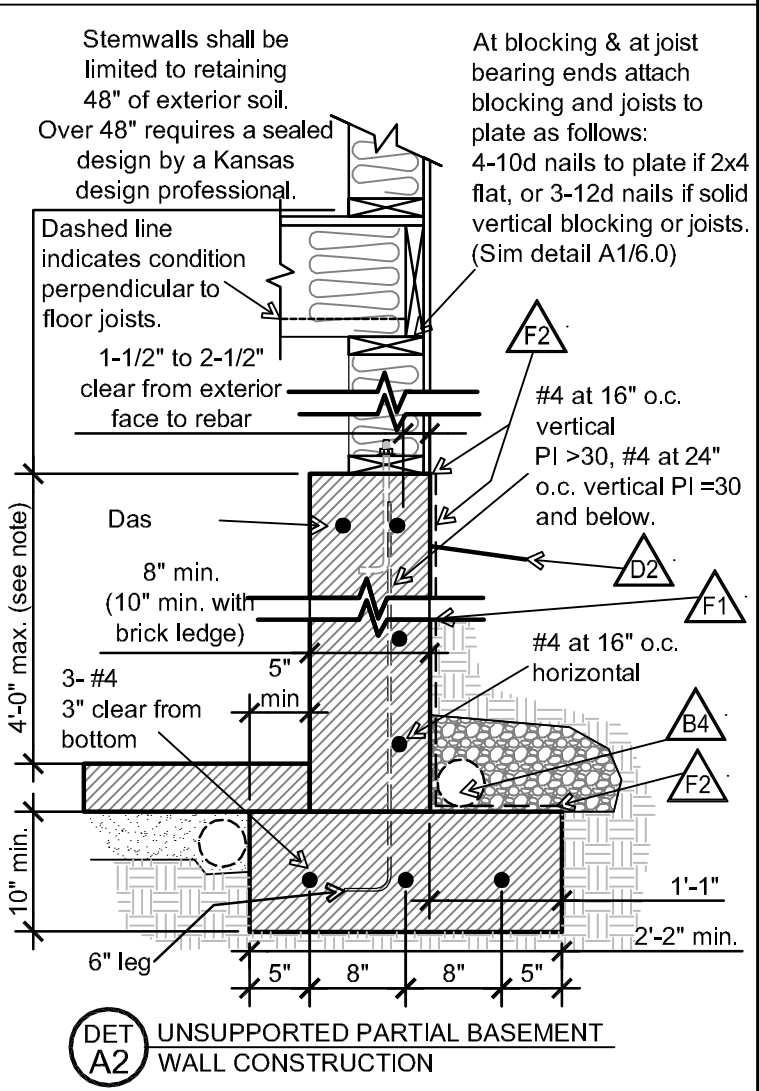
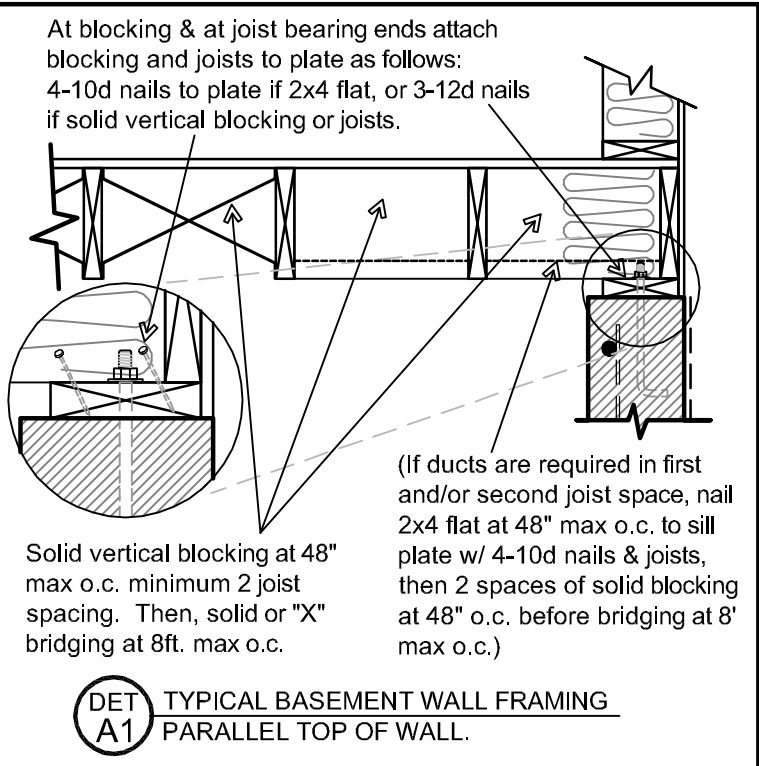
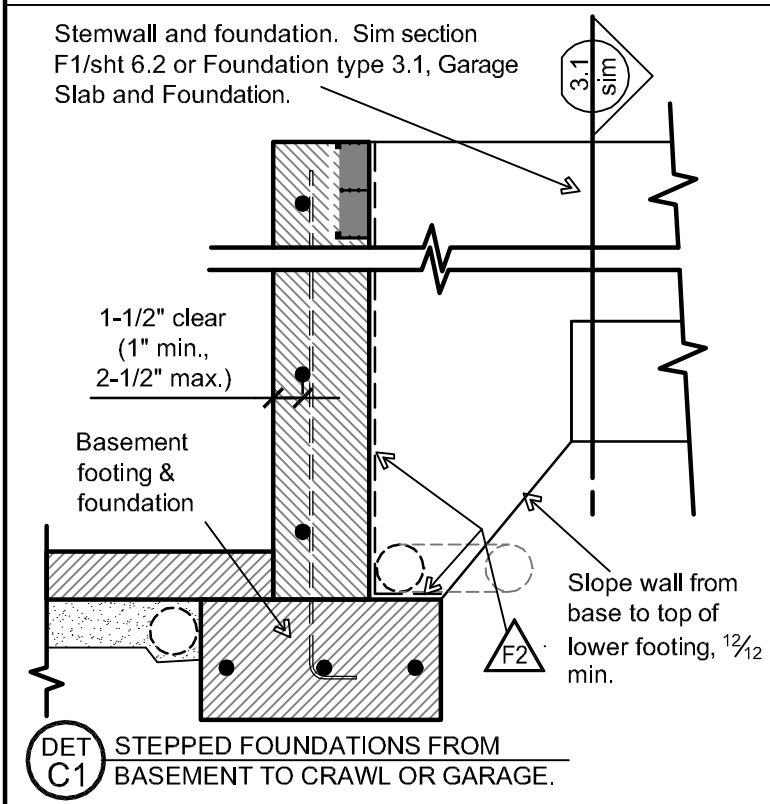
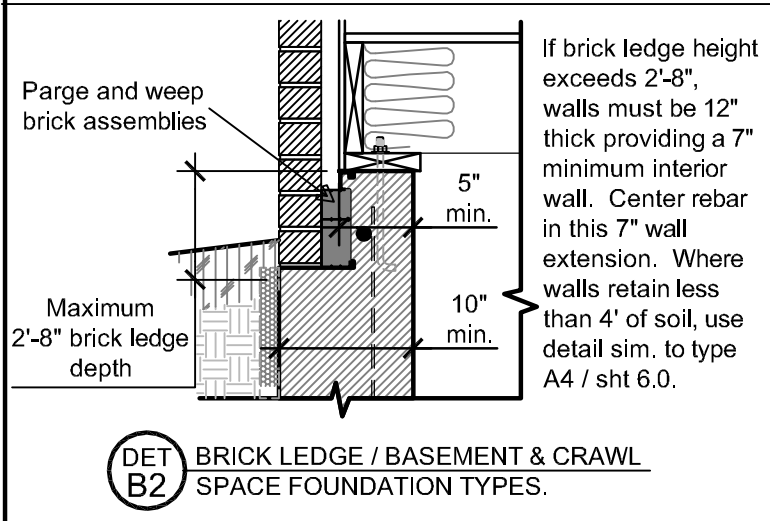
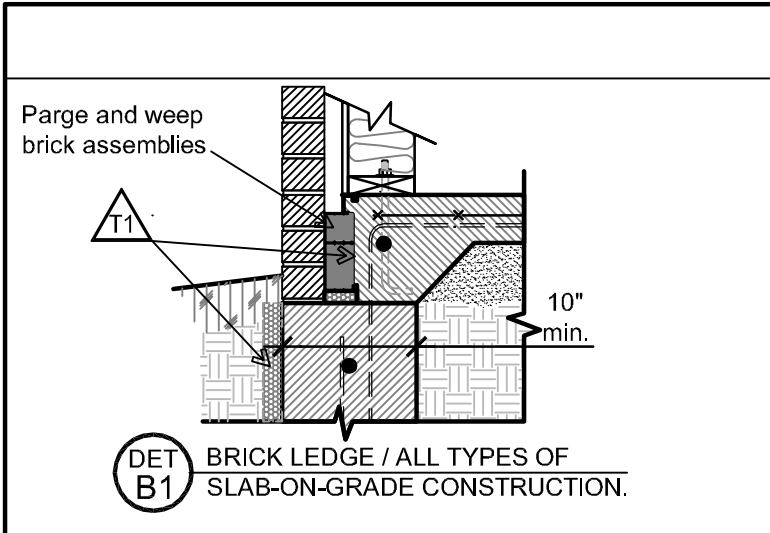

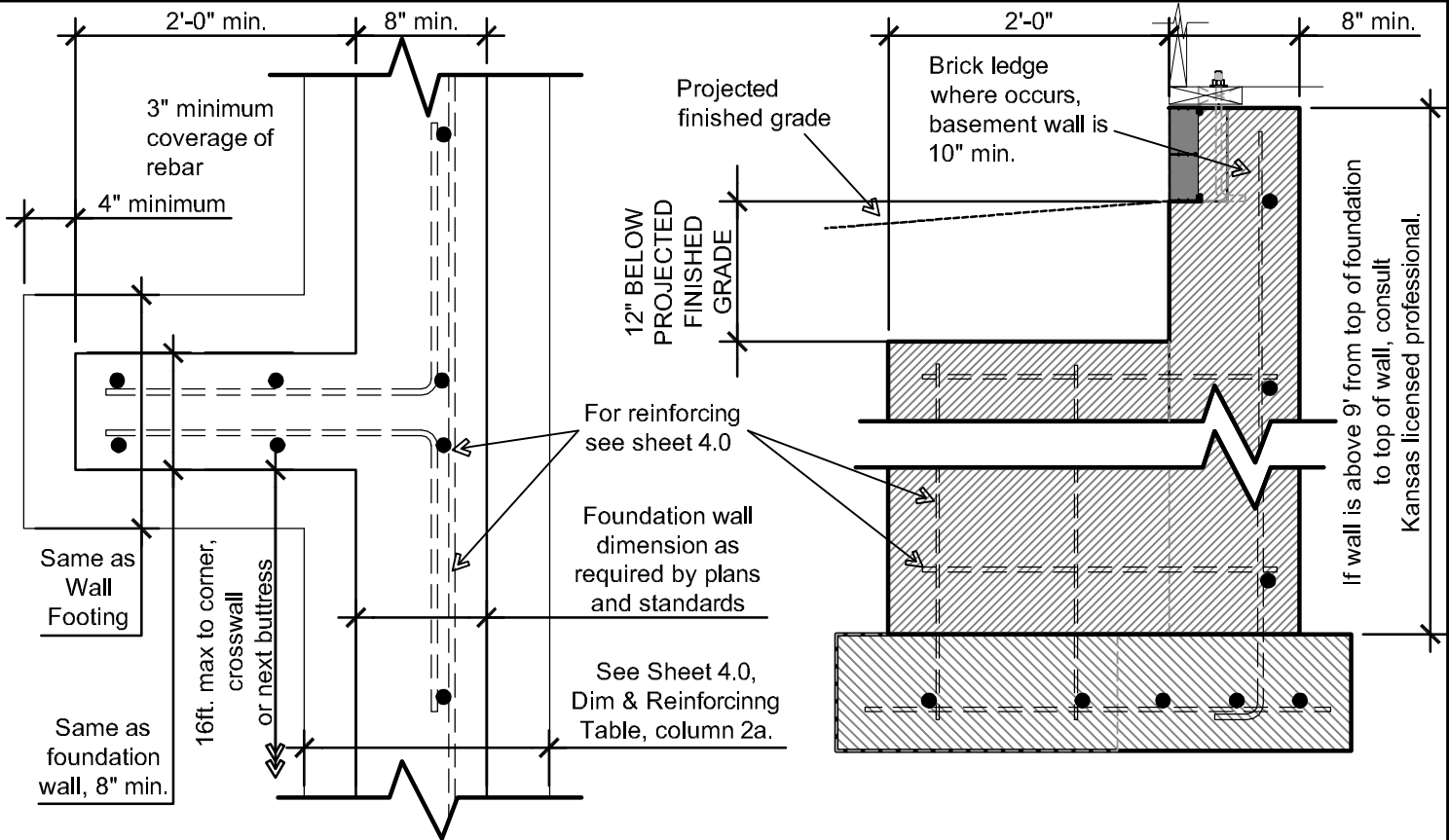

DET D2 FOUNDATION BUTTRESS HORIZONTAL SECTION (Plan view)

DET D1 FOUNDATION BUTTRESS VERTICAL SECTION

3 OPTIONS FOR MEETING BASEMENT WALL INSULATION REQUIREMENTS:

- A. EXTERIOR INSULATION OPTION:**
 1) Install approved XPS or EPS insulation on exterior of foundation, full height, to R-10 min. Use poured-in-place EnergyEdge, post applied flashing or cementitious material to protect exposed insulation at transition.
- B. INTERIOR INSULATION OPTIONS:**
 1) Apply continuous insulation, full height, with EPS or XPS sheet material to R-10 min.
 2) Construct interior stud walls, full height and insulate walls to R-13 min.

Reference table "A", Sheet 0.3, Foundation Insulation Standards, for details on insulation of basement and slab-on-grade projects.

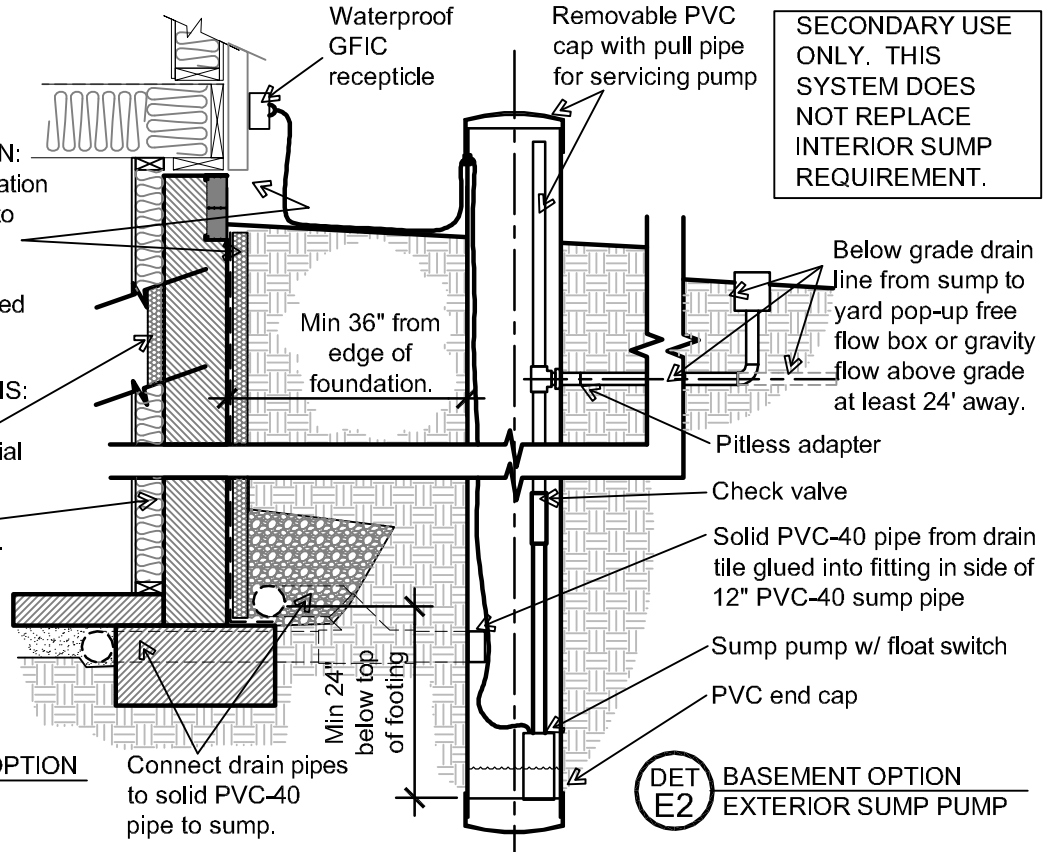

DET E1 BASEMENT INSULATION OPTION WALL INSULATION REQUIREMENTS

DET E2 BASEMENT OPTION EXTERIOR SUMP PUMP

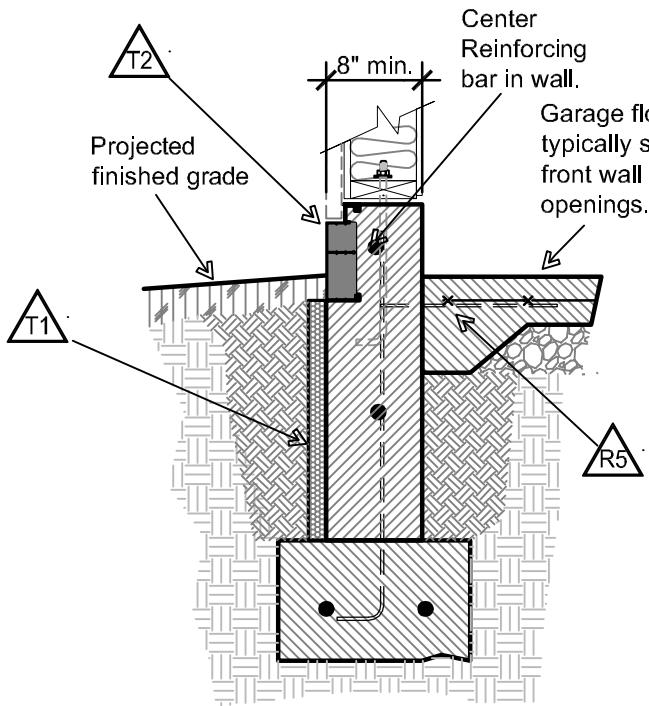

DET F1 GARAGE SLAB & FOUNDATION ALTERNATIVE DETAIL

Reference foundation 3.1, garage slab and foundation detail for reinforcing and dimensioning requirements

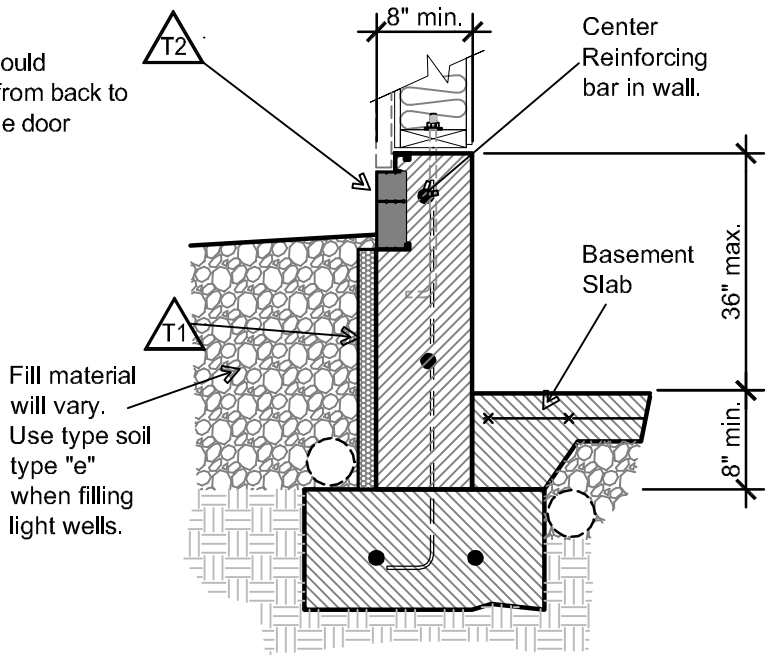

DET F2 PIT or VIEW-OUT BASEMENT WALL SUPPLEMENTAL DETAIL

Similar to basement wall 4.0 detail for reinforcing and dimensioning requirements.

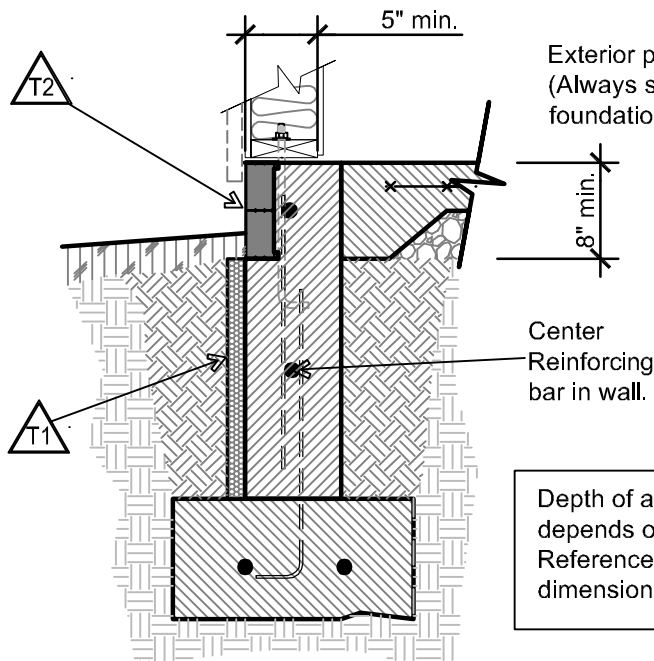

DET F3 FULL ELEVATION FROST-WALL FLOATING INTERIOR SLAB ALTERNATIVE BASEMENT WALK-OUT DETAIL

Similar to foundation 3.0 stemwall and foundation detail for reinforcing and dimensioning requirements

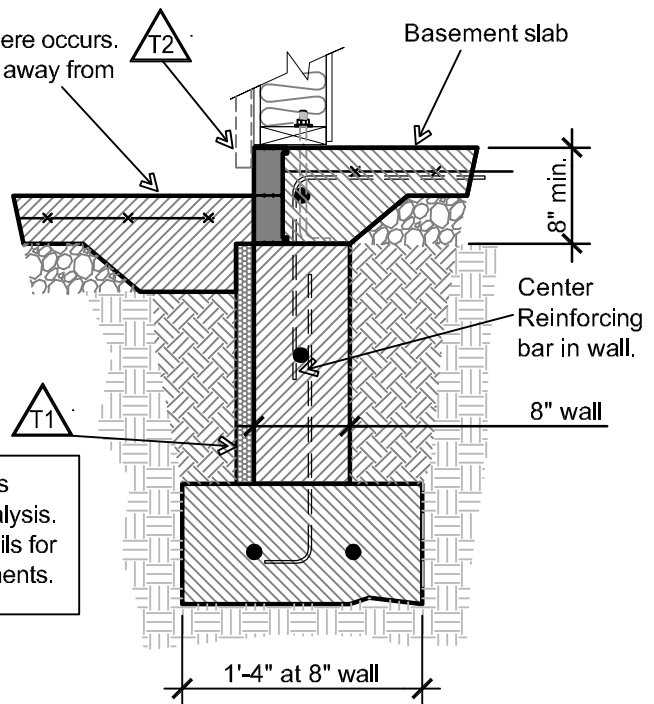

DET F4 WALK-OUT BASEMENT @ EXTERIOR PATIO TRADITIONAL SLAB EDGE

Similar to foundation 3.0 stemwall and foundation detail for reinforcing and dimensioning requirements

Maintaining positive surface drainage away from the foundation edge by adding non-granular (cohesive) soil over settling backfill material will help move water away from the buildings perimeter.

When perimeter soil drainage is not maintained, increased water penetration at foundation promotes soil expansion, greatly increasing damage potential.

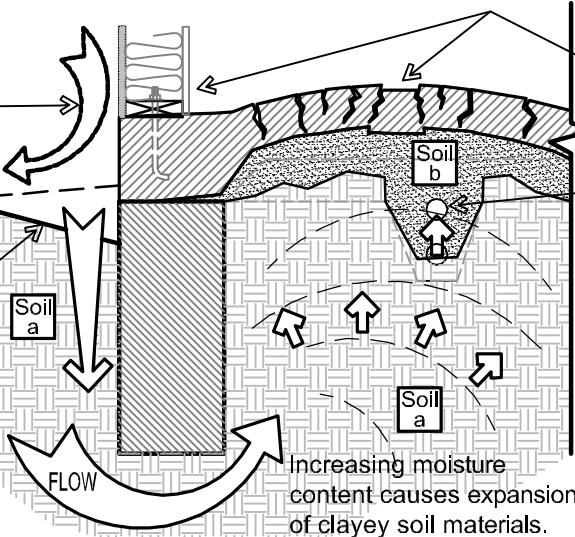

Slabs will heave and foundation edges will separate as a result of soil expansion pressure causing not only physical but structural damage.

When soils below the slab move, below slab water and waste pipes can rupture, further accentuating damaging conditions.

CAUTION! Pouring slabs on top of soils with **LOW (DRY) MOISTURE CONTENT** will promote conditions favorable to "HEAVING". As moisture is drawn INTO soil below the slab, it **EXPANDS**, increasing pressure promotes slab failure. Higher PI soils accentuate this tendency.

SITE S1 INCREASING BELOW GRADE MOISTURE "DOMING" TENDENCY WITH INCREASE PRESSURE

Soil Type "b" provides a buffer for normal seasonal variations in soil moisture content. Extremes in weather, flaws in drainage planning and maintenance, abnormal or existing ground water conditions will accentuate clayey soil movement resulting in damage to slabs and foundation. Where extreme soil or moisture conditions exist or are anticipated it is recommended that a soils engineer be consulted and aggressive subsurface material conditioning be implemented.

"Thermal wicking" of energy from an exposed, uninsulated, foundation edge perimeter can account for 10% to 20% of the heat loss of a home according to the DOE and other Building Science studies.

Deeper foundations in higher PI soils (Soil "a") provide greater protection against thermal and moisture damage, some of these benefits include:

1. Moisture retaining soils (High PI) allow frost (freezing) to penetrate deeper below grade, deeper foundations are required to stay below frost depth; and
2. Moisture variations create swelling and shrinking of clay type soils. The deeper the foundation, the less impact surface water has on soils below the slab.

Increasing the type and amount of reinforcing steel in slabs with higher PI ratings helps to strengthen slabs against failure when soil below experiences differential movement. Proper location of these materials in the slab is critical to performance.

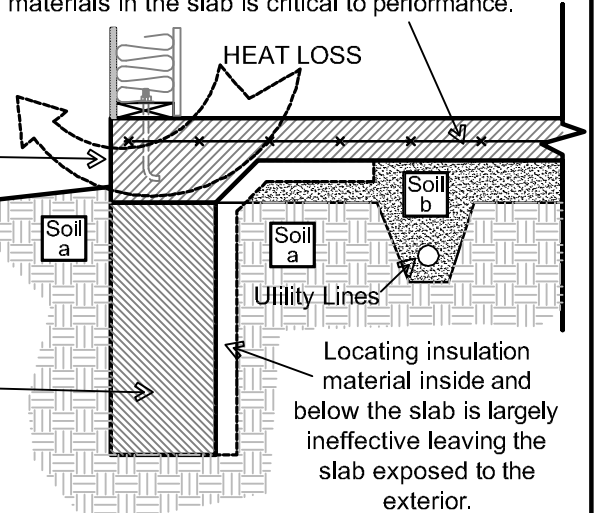

Locating insulation material inside and below the slab is largely ineffective leaving the slab exposed to the exterior.

IMPORTANT NOTE: Foundations depend on even soil bearing in undisturbed soil, consistent in type and free from vegetation, to distribute loading properly. Foundations must be stepped to follow existing site grading conditions, supported on piers or rest in properly tested and compacted fill material. Failure to follow this accepted practice will promote differential settlement over time and is likely to result in foundation, subsequent structural framing and finish material damages.

SITE S2 EXISTING SITE PREPARATION TENDENCIES OF SOIL MATERIALS WITH CHANGING ENVIRONMENTAL CONDITIONS

Dryer soils on exterior wick moisture from below slab, shrinking interior material and bearing capacity.

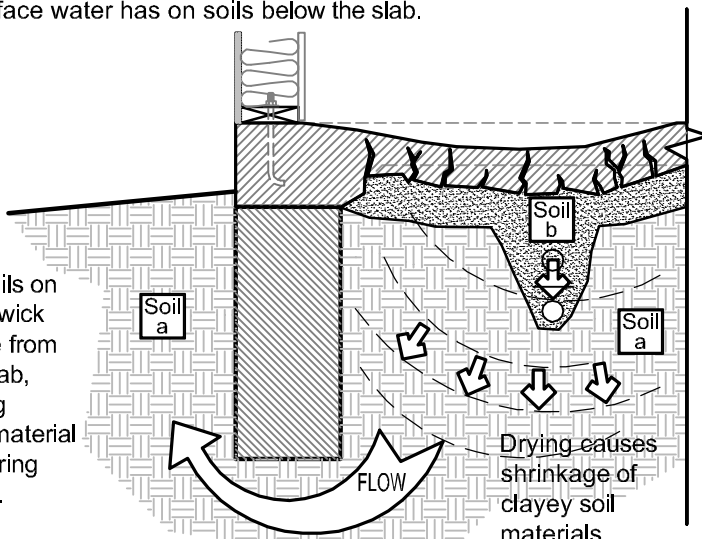

Drying causes shrinkage of clayey soil materials.

CAUTION! Pouring new slabs on soils with **HIGH (WET) MOISTURE CONTENT** will create conditions favorable to "SETTLING". As moisture is wicked out from below the slab soils **SHRINK**, creating "hollows" below the slab. While this condition has a lower potential for structural damage it is a primary cause for slab cracks and separation. Higher PI soils accentuate this tendency.

SITE S3 DECREASING BELOW GRADE MOISTURE "SETTLING" TENDENCY WITH DECREASED PRESSURE